

## TECHNICAL PRODUCT INFORMATION

# AXISS II

## WALL MOUNTED SWIVEL BASIN/BATH MIXER 35MM

### FEATURES & BENEFITS

- Mains pressure only (up to 500kPa)
- Available in chrome & PVD finishes
- 35mm quality European cartridge
- 214mm reach from wall to centre of outlet
- Features 180° swivel spout & pivoting aerator included
- Ideal for kids' safety in bath while maximising space
- Designed & assembled in NZ
- Watermark certified
- 15 year warranty (T&C's apply)



Chrome | AX2SBFCA



Black  
AX2SBFBA

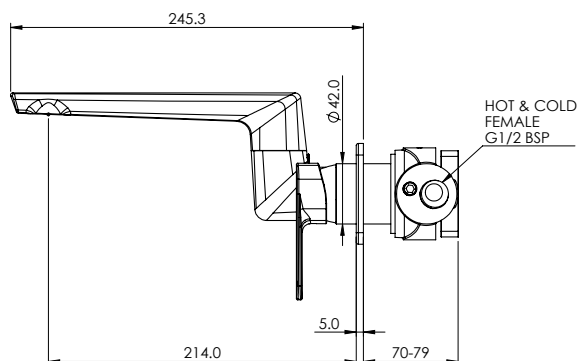
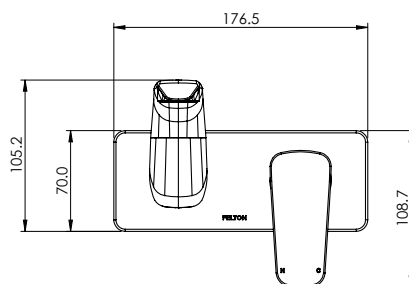

WHEN INSTALLED  
AS BASIN MIXER