

TECHNICAL PRODUCT INFORMATION

AXISS II

WALL MOUNTED BASIN/BATH MIXER 35MM

FEATURES & BENEFITS

- Mains pressure only (up to 500kPa)
- Available in chrome & PVD finishes
- 35mm quality European cartridge
- 174mm reach from wall to centre of outlet
- Pivoting aerator included
- Designed & assembled in NZ
- Watermark certified
- 15 year warranty (T&C's apply)



Chrome | AX2BFCA



Black
AX2BFBA

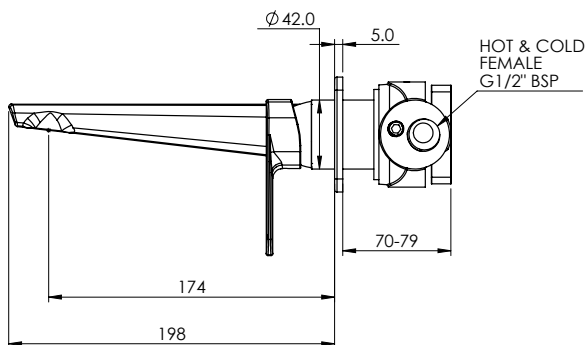
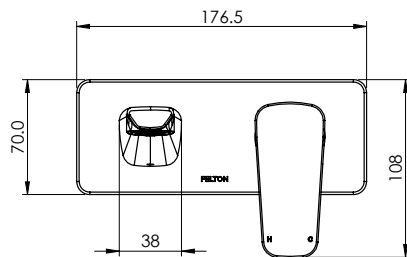

WHEN INSTALLED
AS BASIN MIXER