

# INSTALLATION GUIDE - AUSTRALIA

FELTON

## URBAN SHOWER MIXER UFC5MCA

### SYSTEM REQUIREMENTS

	MINIMUM	MAXIMUM
Equal High (MAINS) Pressures Operating Pressures	20kPa (2.9psi)	1500kPa (217.6psi)
Operating Hot Water Temperatures	55° C	60° C
Operating Cold Water Temperatures	5° C	N/A

⚠ Do not plug outlet when testing.

⚠ This shower mixer can be line tested up 1500kPa (217.6psi)

⚠ This mixer is recommended for equal low or equal high (mains) pressure water supply only.

To ensure the optimum performance and customer satisfaction please adhere to the following:

- Flush out all pipe work prior to installation.
- Minimum flow pressure for satisfactory operation: (Hot and Cold) 36kPa
- Maximum static water pressure: 1500kPa. If the water pressure exceeds or is likely to exceed 1,500kPa, an approved pressure limiting valve must be fitted.
- Maximum hot water temperature: 60°C. If the water temperature exceeds or is likely to exceed 60°C an approved tempering valve must be fitted.
- Installation should comply with relevant local authority requirements.
- In accordance with good plumbing practice, filters should be fitted to supply lines to eliminate damage to the ceramic cartridge from suspended solids.
- AS/NZS 3500.1 states that pressures above 500kPa can cause damage from water hammer, reduce the life of appliances, taps & fittings, cause excessive noise in the system and recommend that a pressure limiting valve (PLV) be fitted.

⚠ Failure to comply with the above will void all warranties.

### WHAT IS IN THE PACK

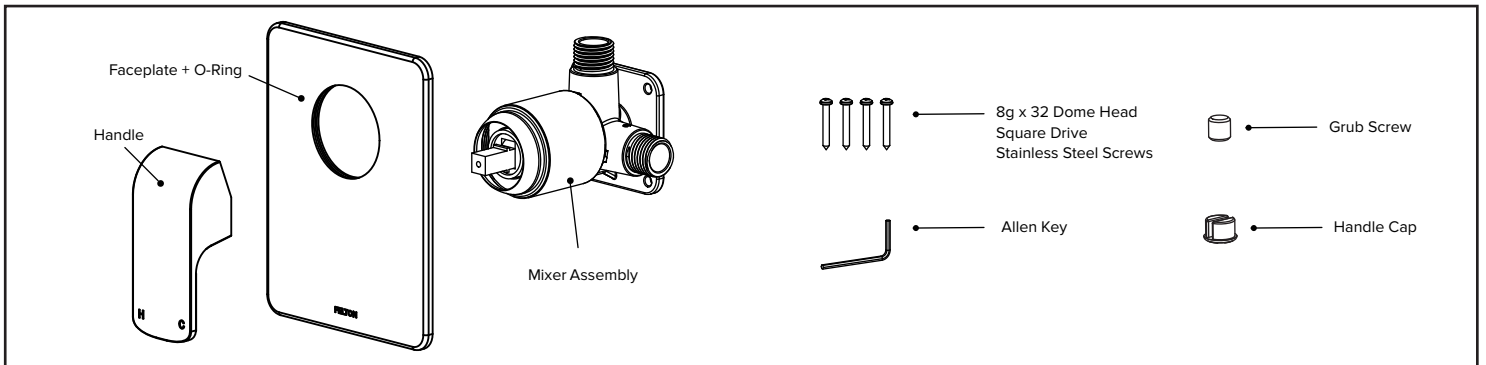

### BEFORE INSTALLATION

Pipework MUST be purged before connecting to the mixer

**HOW TO INSTALL**

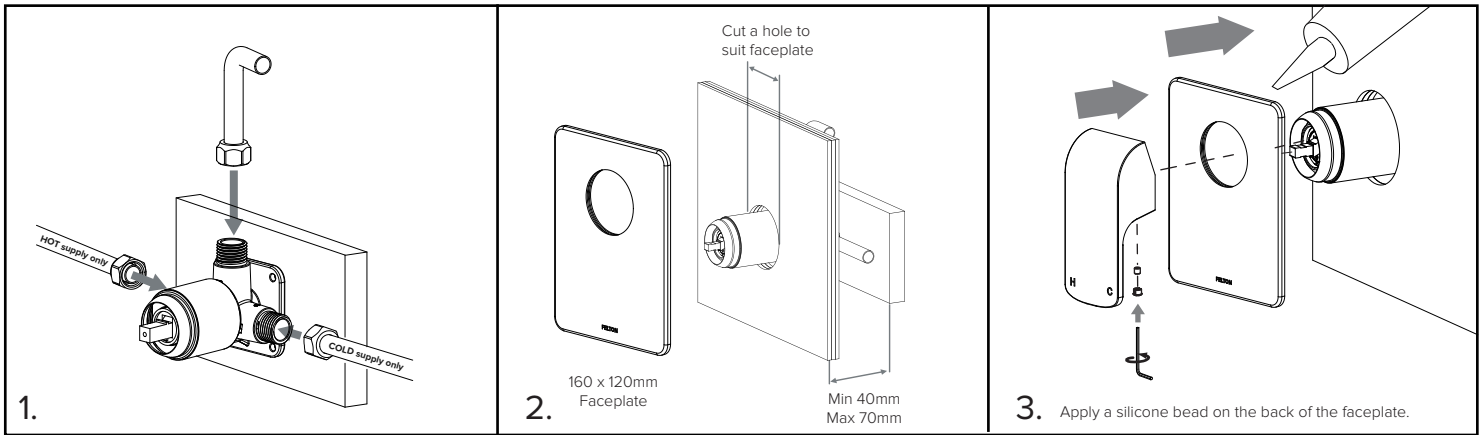

**Warranty, Maintenance and Care YOUR COPY TO KEEP**

Felton Australia Pty Limited guarantees these mixers to be free from defects in materials and workmanship for a period of fifteen (15) years from the date of purchase. Fair wear and tear is expressly excluded. This warranty is effective for fifteen (15) years from the date of purchase and covers the supply of replacement parts only and 2 years of plumber's labour from the date of purchase relating solely to repairing or replacing the mixer, provided the product is installed by a registered plumber. You must retain proof of purchase of the mixer (such as an invoice or receipt) and proof of installation by a registered plumber and provide these to Felton on request. This warranty is for manufacturing defects only and does not cover any damage to the product due to abuse, negligence or improper installation. This warranty is given on the understanding that the product is installed by a registered plumber and operated according to Felton's installation guide and the Australian/New Zealand standard AS/NZS3500. This warranty is provided to persons who are a "consumer" under the Australian Consumer Law only and for use in domestic/residential dwellings only (not for commercial use).



At no stage should any surface coatings be cleaned with cleaning agents that contain a corrosive acid or a scouring additive. Surface coatings should be cleaned with liquid detergent or soap and water. Any damage caused through the use of an unsuitable cleaner will not be covered by this warranty. This warranty is subject to any other rights or remedies that you may have under the Australian Consumer Law (or any other applicable legislation) and to Felton's Terms of Trade.

Please fill in the details below, attach your receipt to this installation guide and keep as your proof of purchase.

Purchased at: .....

Date of purchase: .....

Installed by: .....

**For technical assistance please ring: 1800 792 760**