



INSTALLATION GUIDE - AUSTRALIA

FELTON

REFLEX SINGLE SPRAY SLIDE SHOWER RHSKCSRA

WHAT IS IN THE PACK



Warranty, Maintenance and Care YOUR COPY TO KEEP

FELTON

Felton Australia Pty Limited guarantees these mixers to be free from defects in materials and workmanship for a period of five (5) years from the date of purchase. Fair wear and tear is expressly excluded. This warranty is effective for five (5) years from the date of purchase and covers the supply of replacement parts only, not including installation. You must retain proof of purchase of the Mixer (such as an invoice or receipt) and provide this to Felton on request. This warranty is for manufacturing defects only and does not cover any damage to the product due to abuse, negligence or improper installation. This warranty is given on the understanding that the product is installed and operated according to Felton's installation guide and the Australian/New Zealand standard AS/NZS3500. This warranty is provided to persons who are defined as a "consumer" under the Australian Consumer Law only and for use in domestic/residential dwellings only (not for commercial use).



At no stage should any surface coatings be cleaned with cleaning agents that contain a corrosive acid or a scouring additive. Surface coatings should be cleaned with liquid detergent or soap and water. Any damage caused through the use of an unsuitable cleaner will not be covered by this warranty. This warranty is subject to any other rights or remedies that you may have under the Australian Consumer Law (or any other applicable legislation) and to Felton's Terms of Trade.

Please fill in the details below, attach your receipt to this installation guide and keep as your proof of purchase.

Purchased at:

Date of purchase:

Installed by:



For technical assistance please ring: 1800 792 760

HOW TO INSTALL

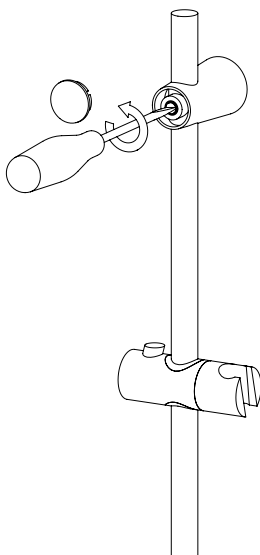
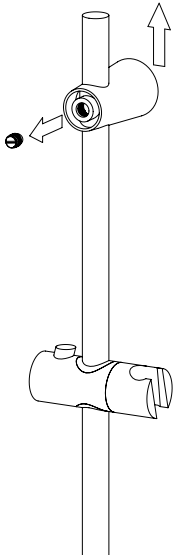
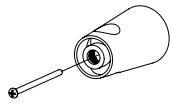
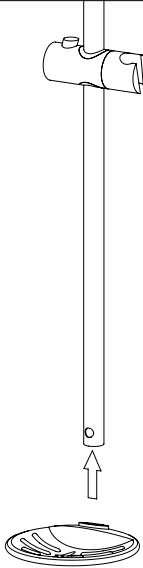
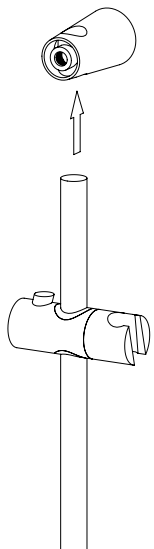
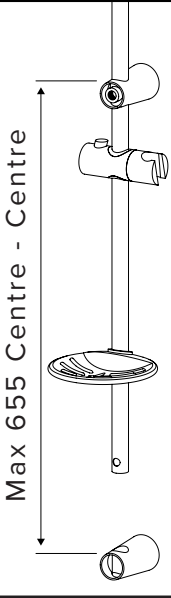
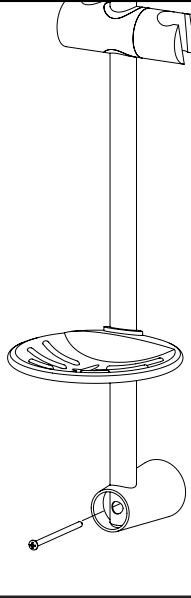
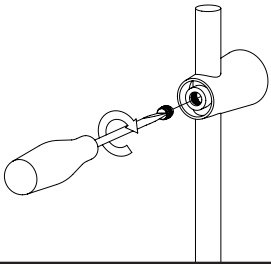
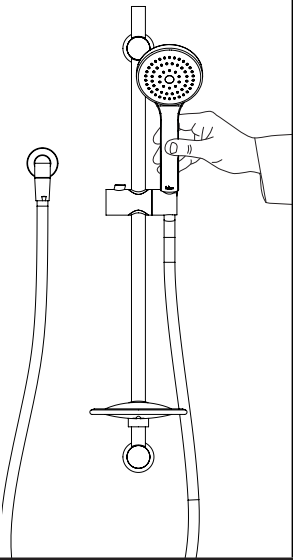
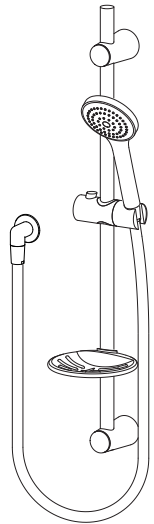
INSTALLING INTO STUD/NOG...(RECOMMENDED)

				
<p>Remove the bracket cap and unscrew the plastic tightener.</p> <p>1.</p>	<p>Remove the adjustable bracket from the rail.</p> <p>2.</p>	<p>Mount the adjustable bracket into the top bracket position (either into a new pre-drilled hole or existing hole).</p> <p>3.</p>	<p>Fit soap dish onto the rail from the bottom.</p> <p>4.</p>	<p>Slide the rail into the top bracket.</p> <p>5.</p>
 <p>Max 655 Centre - Centre</p>				
<p>Hold the rail and position the bottom bracket into the desired position (max distance 655mm C-C).</p> <p>6.</p>	<p>Mount the bottom bracket into place. Ensure that both rail and bracket are secured. It is recommended that silicone sealant be used to seal the fixing brackets.</p> <p>7.</p>	<p>Screw the plastic tightener into place.</p> <p>Fit bracket caps.</p> <p>8.</p>	<p>Screw the elbow into the water outlet (wingback). Sealant required on thread to achieve a water tight seal. For Mains Pressure, fit flow restrictor into the handpiece first. Screw the hose onto the elbow and handpiece and attach the handpiece to the slider on the rail.</p> <p>9.</p>	

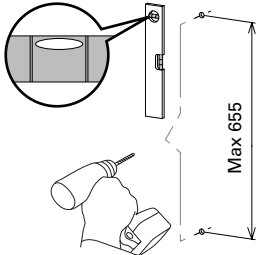
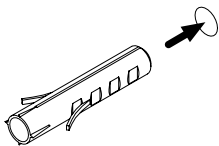
INSTALLING INTO CONCRETE/BRICK WALL...

<p>Pre-drill holes to the desired position (Max 655mm Centre - Centre) and fit the wall anchors then follow the above instruction.</p>			
--	---	--	---