

INSTALLATION GUIDE - AUSTRALIA

FELTON

DESIGNER III FELTONMIX™ SHOWER COMBO EQUAL HIGH CHROME GREY D3SCHCGA

SYSTEM REQUIREMENTS

	MINIMUM	MAXIMUM
Equal High (Mains) Pressures - Feltonmix Type H (Pink Rotor) Operating Pressures [Flow Pressure]	150kPa (21.8psi)	500kPa (72.5psi)
Operating Hot Water Temperatures	55° C	60° C
Operating Cold Water Temperatures	5° C	N/A

⚠ To ensure the optimum performance and customer satisfaction please adhere to the following:

- Flush out all pipe work prior to installation.
- Maximum hot water temperature is 60°C. If the water temperature exceeds 60°C, an approved tempering valve must be fitted.
- Installation should comply with relevant local authority requirements.
- Filters are fitted to protect parts from damage caused by water born particles. Removal of these filters may void the warranty.
- AS/NZS 3500.1 states that pressures above 500 kPa can cause damage from water hammer, reduce the life of appliances, taps & fittings, cause excessive noise in the system and recommend that a pressure limiting valve (PLV) be fitted.

⚠ Failure to comply with the above will void all warranties.



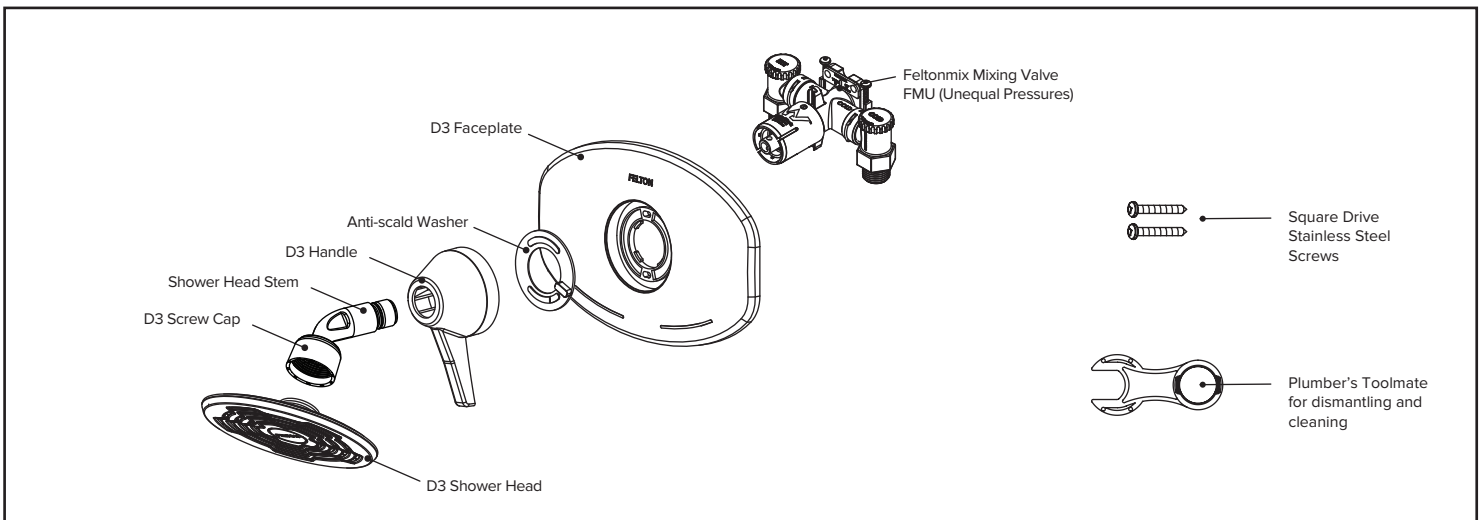

WHAT IS IN THE PACK



HOW TO INSTALL

1. Secure valve to suitable fixing at a comfortable height approx. **1.8m** from the finished floor and **45mm** from the back of the mixer to the finished wall lining.
2. Once the mixer is fitted it is important any pipework that is fitted to the isolators does not put any unnecessary stress on the valve assembly.
3. Make the correct access hole to the mixer.
- 4A. Using the two screws provided tighten the faceplate to the mixer making sure not to overtighten.
- 4B. If fitting anti-scald washer (optional), position the anti-scald washer over the faceplate recess and secure by fitting the two screws provided through the slots of the anti-scald washer and faceplate then tighten them to the mixer making sure not to overtighten.
5. With the mixer in the off position slide the handle onto the white slotted sleeve on the mixer checking that the handle is central to the wallplate. If not remove the handle, reposition and tighten wallplate and refit the handle.
6. Screw in shower head stem with screw cap until fully tighten. If required, unscrew the shower head stem partly to the desired position. **DO NOT** put tape or hemp on the thread as the o-ring seal fitted to the shower head stem will ensure a watertight seal.
7. Ensure the rubber seal for shower head is in position then fit and tighten the shower head to the screw cap and stem.
8. Check the operation of the mixer.
9. Ensure handle moves freely and no leaks are detected around the handle.

TROUBLE SHOOTING...

<p> INSUFFICIENT WATER FLOW</p>	<p> INSUFFICIENT HOT WATER</p>
<p>Check that the correct model (Type U, Type E or Type H) has been installed for the supply conditions. Check filters for foreign matter.</p>	<p>Check that isolators are fully open (unscrewed anti-clockwise). Check that sufficient water pressure is reaching the valve. A minimum of 20kPa flow pressure is recommended.</p>
<p> VALVE DOES NOT SHUT OFF PROPERLY</p>	<p> WATER LEAKS FROM BEHIND</p>
<p>Check inlet seals are correctly fitted. Check rotor for any damage. Rotor should be smooth and free from any deep scratches or grooves.</p>	<p>If water is leaking from under slotted sleeve when shower is on it will be necessary to replace O-ring seals on rotor.</p>

TO REPLACE SEALS AND SPRINGS...

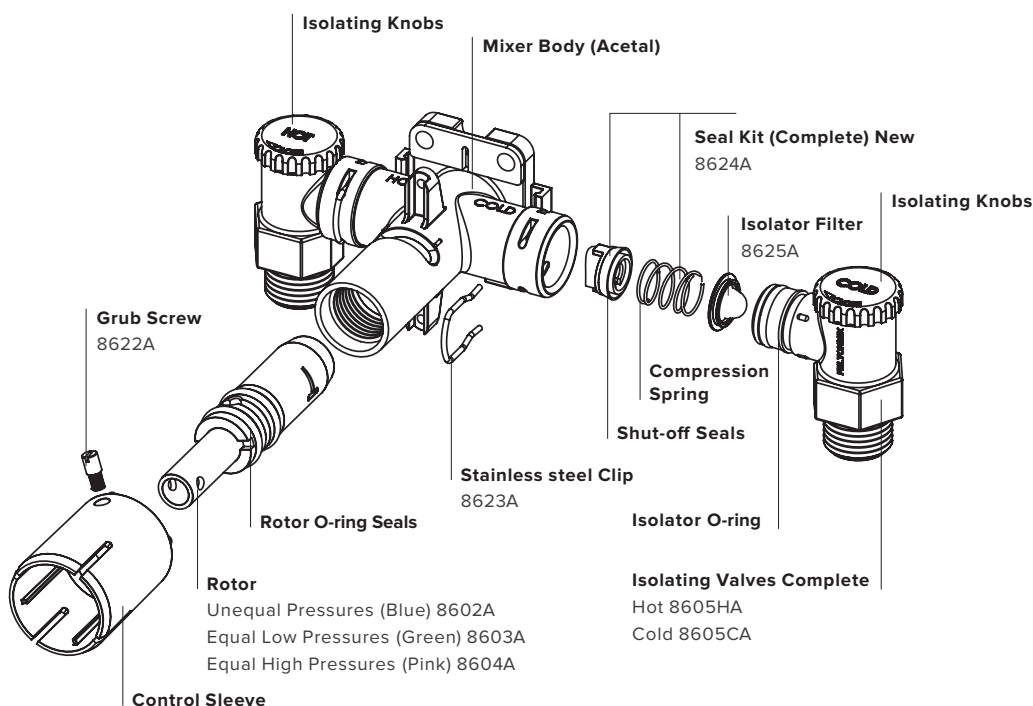

A rubber shut-off seal and spring is fitted in each of the two inlets of the valve body and two O-ring seals fitted to the rotor located inside the valve body.

1. Unscrew shower head and stem from valve body.
2. Using both hands support the handle top and bottom and withdraw from valve body.
3. Remove wallplate by unscrewing the two 25mm x 7 fixing screws.
4. Turn off water supply at either the mains or the shower mixer isolators.
5. Gently prise stainless steel retaining clips on valve body outwards with screwdriver and remove clips completely. Pull isolators clear of valve body.
6. Unscrew mixer retaining screws and remove mixer from wall.
7. Remove grub screw from control sleeve.
8. Withdraw rotor from body using a suitable tool through cross hole in rotor.
9. Using seal extractor tool supplied with the replacement seal pack, insert end marked 'REMOVE' fully into hole in centre of seal and withdraw seal and spring.
10. Fit blade of seal extractor tool end marked 'REPLACE' into slots in bore of new seal and spring.
11. Fit seal in inlet bore with turning motion until lugs on seal engage in slots in bore of inlet. Push fully home.
12. Discard O-Ring seals on rotor. Replace with new O-Ring seals.
13. Discard isolator O-Rings and fit new O-Rings supplied.
14. Re-assemble in reverse manner. Insert rotor in body. Fit isolators to mixer body. Insert stainless steel retaining clips through slots in valve body and press fully home.

Filters

Each isolator is fitted with a filter. These filters can be easily prised out, cleaned and snapped back into place.

CLEANING THE SHOWER HEAD DESIGNER III SHOWER HEAD

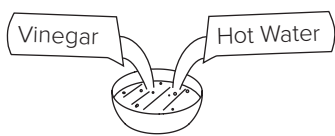
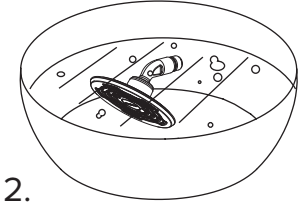
<p>Your Feltonmix shower head is manufactured from self-cleaning plastic materials but if cleaning is required use a combination of vinegar and water and by following the steps below is usually sufficient.</p> <ol style="list-style-type: none"> 1. Remove shower rose from the showerhead stem. 2. Place shower rose in a mixed solution of vinegar and hot water for between 15 – 20 min. (Note: the face of the shower rose cannot be removed for cleaning purposes.) <p>If extra cleaning is still required use a soft brush.</p>	<p style="text-align: center;">1:1</p>  <p>1.</p>	<p style="text-align: center;">15 - 20 mins</p>  <p>2.</p>
---	---	---

Warranty, Maintenance and Care YOUR COPY TO KEEP

Felton Australia Pty Limited guarantees these mixers to be free from defects in materials and workmanship for a period of five (5) years from the date of purchase. Fair wear and tear is expressly excluded. This warranty is effective for five (5) years from the date of purchase and covers the supply of replacement parts only, not including installation. You must retain proof of purchase of the Mixer (such as an invoice or receipt) and provide this to Felton on request. This warranty is for manufacturing defects only and does not cover any damage to the product due to abuse, negligence or improper installation. This warranty is given on the understanding that the product is installed and operated according to Felton's installation guide and the Australian/New Zealand standard AS/NZS3500. This warranty is provided to persons who are defined as a "consumer" under the Australian Consumer Law only and for use in domestic/residential dwellings only (not for commercial use).



At no stage should any surface coatings be cleaned with cleaning agents that contain a corrosive acid or a scouring additive. Surface coatings should be cleaned with liquid detergent or soap and water. Any damage caused through the use of an unsuitable cleaner will not be covered by this warranty. This warranty is subject to any other rights or remedies that you may have under the Australian Consumer Law (or any other applicable legislation) and to Felton's Terms of Trade.

Please fill in the details below, attach your receipt to this installation guide and keep as your proof of purchase.

Purchased at:

Date of purchase:

Installed by:

For technical assistance please ring: 1800 792 760