



# INSTALLATION GUIDE - AUSTRALIA

FELTON

## AXISS VEGE SPRAY SINK MIXER AXSMSCA

### SYSTEM REQUIREMENTS

To ensure the optimum performance and customer satisfaction please adhere to the following:

- Flush out all pipe work prior to installation.
- Maximum hot water temperature is 60°C. If the water temperature exceeds 60°C an approved tempering valve must be fitted.
- Installation should comply with relevant local authority requirements.
- In accordance with good plumbing practice, filters should be fitted to supply lines to eliminate damage to the ceramic cartridge from suspended solids.
- AS/NZS 3500.1 states that pressures above 500 kPa can cause damage from water hammer, reduce the life of appliances, taps & fittings, cause excessive noise in the system and recommend that a pressure limiting valve (PLV) be fitted.

MAXIMUM STATIC PRESSURE
Maximum static pressure 1500kPa. If water pressure exceeds or is likely to exceed 1500kPa, an approved pressure limiting valve must be fitted.

MINIMUM STATIC PRESSURE	HOT	COLD
Mains Pressure	150kPa	150kPa



**Failure to comply with the above will void warranties**

### WHAT IS IN THE PACK

1 x sink mixer	1 x hex socket spanner	2 x male female brass nipples
2 x supply hoses	2 x filters	2 x plastic sleeves
1 x sink fixing kit		

### MAINS PRESSURE

Install product as supplied and ensure M&F nipple and filters are fitted to water supply.

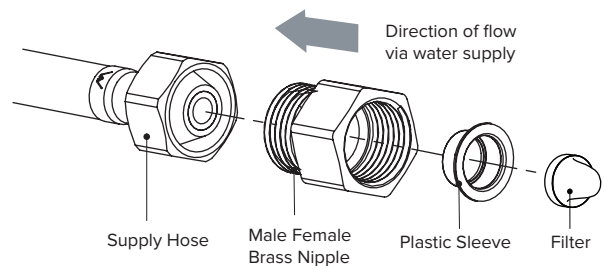

## HOW TO INSTALL

1. Cut a mounting hole 35mm in diameter. There must be a minimum 20mm width of flat around the hole.
2. Fit benchtop o-ring seal to base groove of mixer.
3. Screw the threaded studs into mixer base.
4. Screw the "HOT" supply hose (with RED marking) into left hand hole of mixer base.
5. Screw the "COLD" supply hose into right hand hole of mixer base.
6. Lower the fitted hoses, one hose at a time, into mounting hole.
7. From UNDERNEATH the bench, fit the rubber horseshoe washer (if supplied), and metal horse shoe washer around both hoses and over the threaded studs.
8. Screw on the fixing nuts and tighten with fingers.
9. Check the mixer and the benchtop seal are correctly aligned on the bench. Secure with spanner.
10. Flush the supply pipes to remove debris.
11. Connect the water supply with the appropriate fittings and check all the fittings are tight.

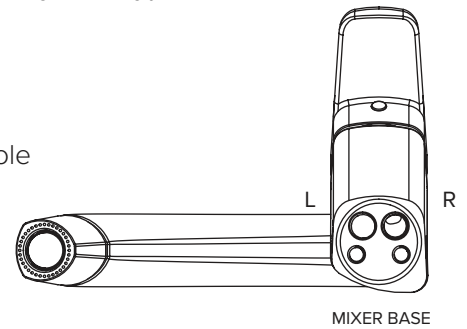

**It is essential that filters are installed with the brass nipples to prevent the clogging of the vege spray mechanism.**

12. Turn on water supply and check for leaks.

**Maximum bend for flexible hose is 35mm radius. The nipples on the hoses must be connected to fittings which have machined end faces, not "sawn off" threaded tube.**

## Warning, Maintenance and Care YOUR COPY TO KEEP

Felton Australia Pty Limited guarantees these mixers to be free from defects in materials and workmanship for a period of fifteen (15) years from the date of purchase. Fair wear and tear is expressly excluded. This warranty is effective for fifteen (15) years from the date of purchase and covers the supply of replacement parts only and 2 years of plumber's labour from the date of purchase relating solely to repairing or replacing the mixer, provided the product is installed by a registered plumber. You must retain proof of purchase of the mixer (such as an invoice or receipt) and proof of installation by a registered plumber and provide these to Felton on request. This warranty is for manufacturing defects only and does not cover any damage to the product due to abuse, negligence or improper installation. This warranty is given on the understanding that the product is installed by a registered plumber and operated according to Felton's installation guide and the Australian/New Zealand standard AS/NZS3500. This warranty is provided to persons who are a "consumer" under the Australian Consumer Law only and for use in domestic/residential dwellings only (not for commercial use).



At no stage should any surface coatings be cleaned with cleaning agents that contain a corrosive acid or a scouring additive. Surface coatings should be cleaned with liquid detergent or soap and water. Any damage caused through the use of an unsuitable cleaner will not be covered by this warranty. This warranty is subject to any other rights or remedies that you may have under the Australian Consumer Law (or any other applicable legislation) and to Felton's Terms of Trade.

Please fill in the details below, attach your receipt to this installation guide and keep as your proof of purchase.

Purchased at: .....

Date of purchase: .....

Installed by: .....

**For technical assistance please ring: 1800 792 760**